

## NUQ SERIES ENGINEERING INFORMATION

**The NuQ-8 is an ultra-compact loudspeaker system designed for use in a wide range of portable speech and music sound reinforcement applications.**

The NuQ-8 loudspeaker is designed to work in conjunction with a Turbosound LMS Series loudspeaker management system and Turbosound T series amplifiers. This combination provides the optimum performance from the system as well as offering considerable flexibility to readily adapt to varying venue requirements. NuQ systems can also be controlled over a BVNet network using TurboDrive™ control software.

The passive two-way NuQ-8 loudspeaker features a front-loaded 8" neodymium low frequency driver and a proprietary 1" neodymium high frequency compression driver on a rotatable 100°H x 60°V HF Converging Elliptical (CEW™) waveguide matched with an internal passive crossover network in a reflex-loaded enclosure. The comparatively short HF flare allows accurate physical alignment of the HF and LF devices, and ensures that the wavefront is shaped smoothly while giving excellent pattern control. The waveguide can be rotated through 90° within the enclosure, making it possible to swap the horizontal and vertical coverage patterns.



The quasi-trapezoidal enclosure is uniquely formed out of pre-bent plywood, which entirely eliminates four cabinet joints and provides additional benefits of superior strength, low weight and reduced internal reflections. The symmetrical cabinet shape, together with the possibility to rotate the HF horn pattern, creates an additional role as mirrored left/right monitor wedges as well as for front-of-house applications.

The cabinet includes rigging points for use with optional flying yokes, wall brackets and swivel brackets, and also provides compatibility with OmniMount™ wall and ceiling brackets. A pole mount socket is fitted to the bottom of the cabinet for use with 35mm poles and speaker stands.

The cabinet is constructed from 12mm (1/2") birch plywood, screwed and glued together for maximum strength and rigidity, and includes a steel mesh grille backed with reticulated foam. It is finished in durable black semi-matt textured paint; white textured paint is optionally available.

A rear panel connector plate carries two Neutrik Speakon NL4MP connectors for loop in and loop out connections to additional enclosures. The cabinet is provided with a flush handle for easy handling.

### FEATURES

- CEW™ technology**
- Bent plywood construction**
- Rotatable HF waveguide**
- Compact enclosure**
- Multiple rigging points**
- Pole mount socket**
- OmniMount™ compatible**

### APPLICATIONS

- Front of house**
- Floor monitoring**
- Dry hire and rental**
- Theatre**
- Audio-visual**
- Houses of Worship**
- Corporate / industrial**

<b>DIMENSIONS (HxWxD)</b>	464mm x 272mm x 220mm (18.3" x 10.7" x 8.7")	
<b>NET WEIGHT</b>	9.5kg (20.9lbs)	
<b>COMPONENTS</b>	1 x 8" (203mm) LF driver, 1 x 1" (25mm) HF driver on a Converging Elliptical Waveguide™	
<b>FREQUENCY RESPONSE<sup>1</sup></b>	60Hz - 20kHz ±4dB	
<b>NOMINAL DISPERSION<sup>2</sup></b>	100°H x 60°V@-6db points. Rotatable waveguide allows swap of horizontal and vertical pattern	
<b>POWER HANDLING</b>	250 watts continuous, 500 watts program Recommended amplifier power: 500 watts @ 8 ohms	
<b>SENSITIVITY<sup>3</sup></b>	94dB	
<b>CALCULATED MAX SPL</b>	118dB continuous <sup>4</sup> , 124dB peak <sup>5</sup>	
<b>CROSSOVER</b>	Internal passive crossover at 2k5Hz; 24dB/octave Butterworth	
<b>CONTROLLERS</b>	Turbosound LMS-D24, LMS-D26	
<b>NOMINAL IMPEDANCE</b>	8 ohms	
<b>CONSTRUCTION</b>	12mm (1/2") birch plywood; rebated, screwed and glued. Finished in black semi-matt textured paint. One recessed carrying handle. Integral pole mount socket	
<b>GRILLE</b>	Powder coated perforated steel with acoustically transparent reticulated foam	
<b>CONNECTORS</b>	(2) Speakon NL4MP, wired pin1+: positive, pin1-: negative, pins 2+ and 2- n/c	
<b>FLYING HARDWARE</b>	M8 rigging points for WB-20B wall brackets and OmniMount™ 20.5 series brackets M8 rigging point for NuQ-SB8 swivel brackets M10 rigging points for NuQ-FY8 flying yokes and EB-10 shoulder eyebolts	
<b>OPTIONS</b>	Optional colour: white textured paint	
<b>SPARES AND ACCESSORIES</b>	LS-8093	8" (203mm) LF loudspeaker
	RC-8093	Recone kit
	CD-115	1" (25mm) HF compression driver
	RD-115	Replacement HF diaphragm
	PX-NuQ8	Crossover network
	MG-NuQ8	Replacement grille
	WB-20B	Wall bracket
	NuQ-FY8	Flying yoke
	NuQ-SB8	Swivel bracket
	PB-55	Wall bracket, pole mount fixing

**Notes**

<sup>1</sup>Measured on axis

<sup>2</sup>Average over stated bandwidth

<sup>3</sup>Characteristic sensitivity as measured to IEC 268-5

<sup>4</sup>Unweighted diode-clipped pink noise. Measured in a half space environment

<sup>5</sup>Verified by subjective listening tests of familiar program material, before the onset of perceived signal degradation

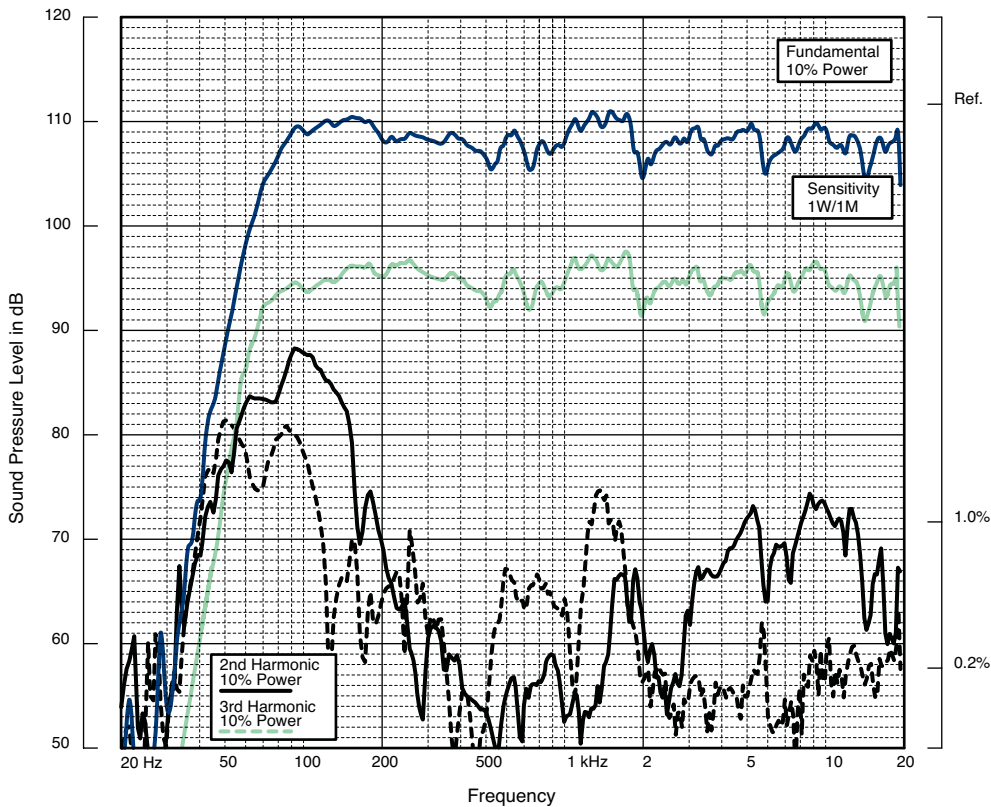

**FREQUENCY RESPONSE**

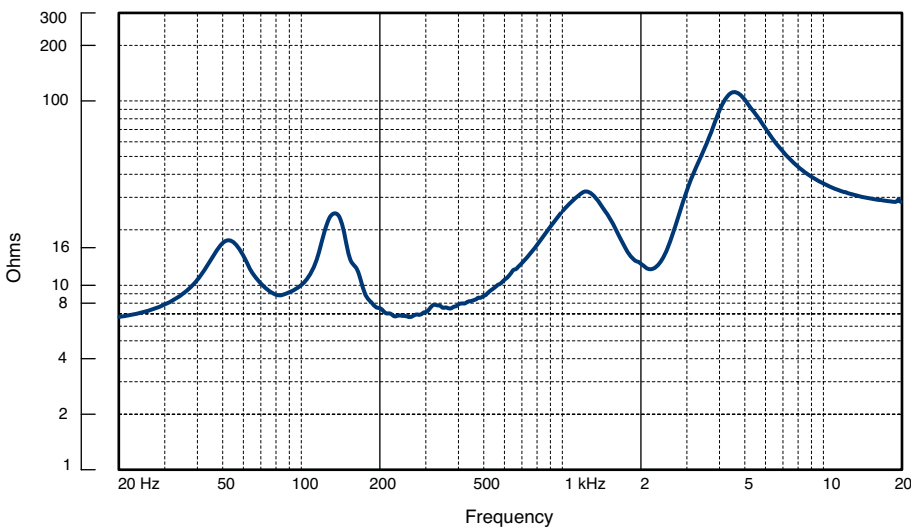

**IMPEDANCE**

**Impedance** A constant current circuit was used to measure the impedance. **Frequency response** The frequency response shown was obtained by feeding a swept sine wave through an unprocessed loudspeaker system in a half space environment. The position of the microphone was vertically on-axis at a distance of 2 metres, then scaled to represent 1 metre. **2nd & 3rd Harmonic Distortion** Distortion measurements were obtained using an Audio Precision harmonic distortion analysis system and comply with AES recommendations for enclosure measurement (AES paper ANSI S4-26-1984). **Data Conversion** All graphs were digitally generated using the APEX custom software system, designed to translate data derived from Audio Precision 'System One' test equipment into AutoCAD™. This program enables graphical information to be plotted to a high degree of accuracy.

**NOTES ON MEASUREMENT CONDITIONS**

**HORIZONTAL THIRD  
OCTAVE POLARS**

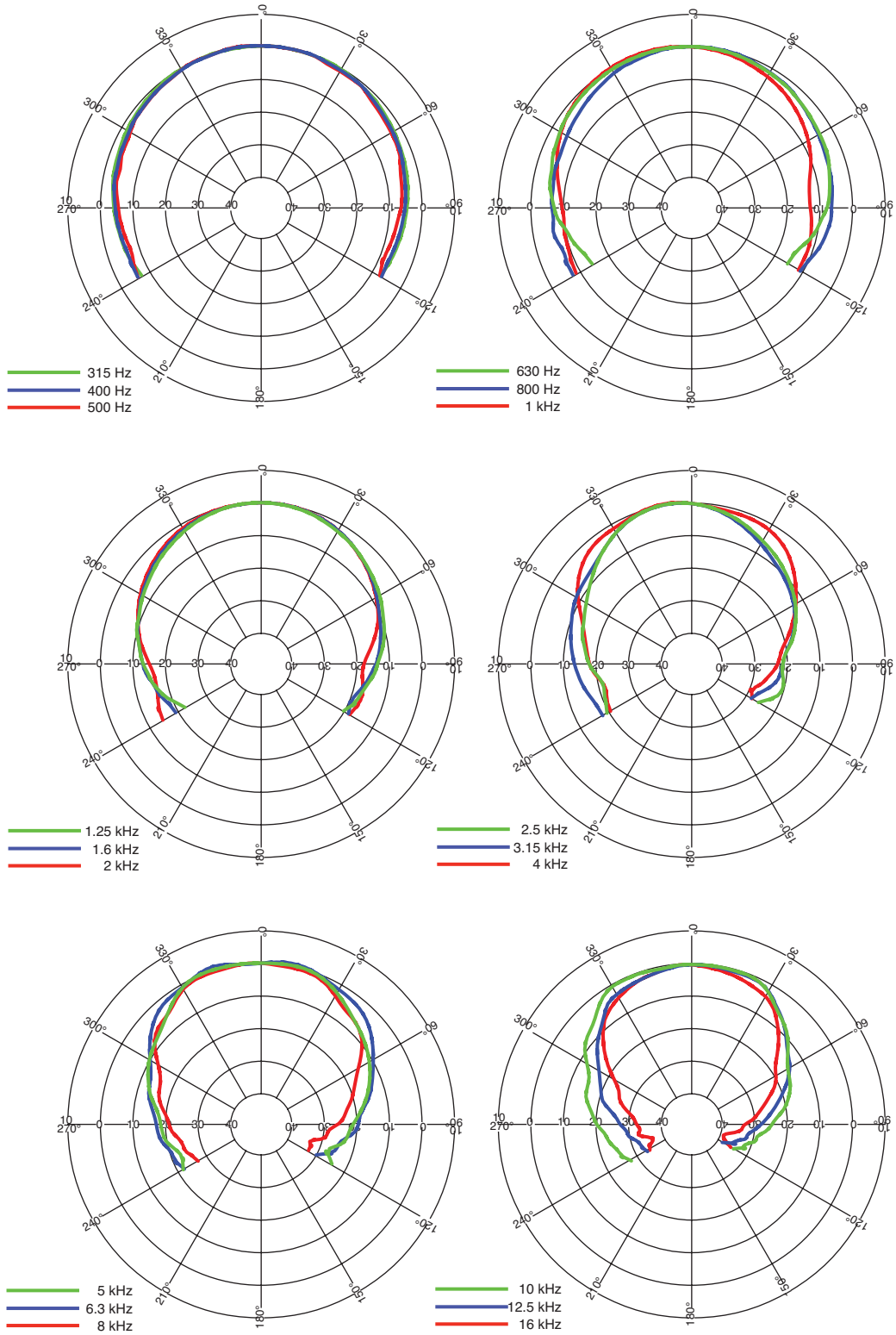

**VERTICAL THIRD OCTAVE POLARS**

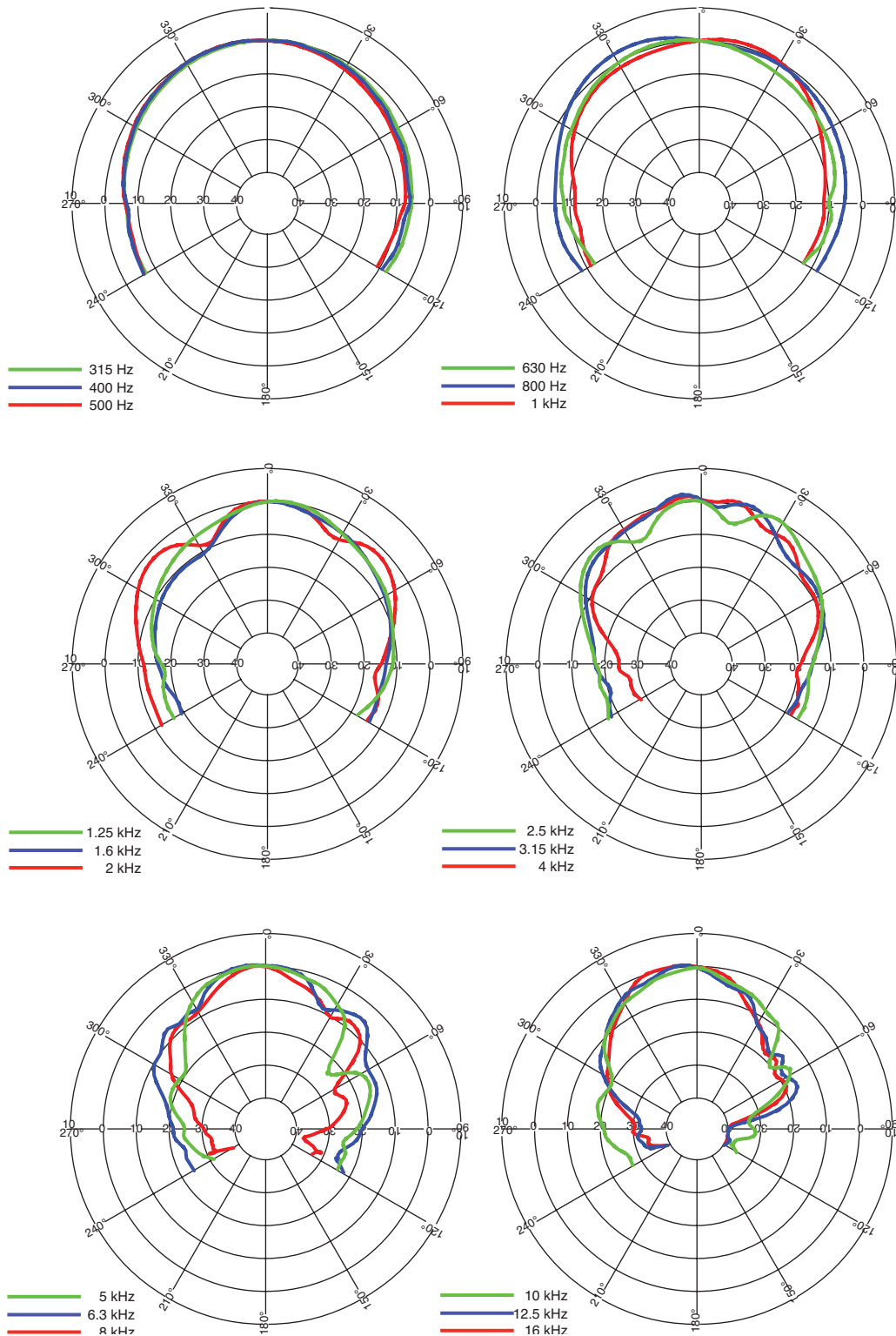

**BEAMWIDTH**

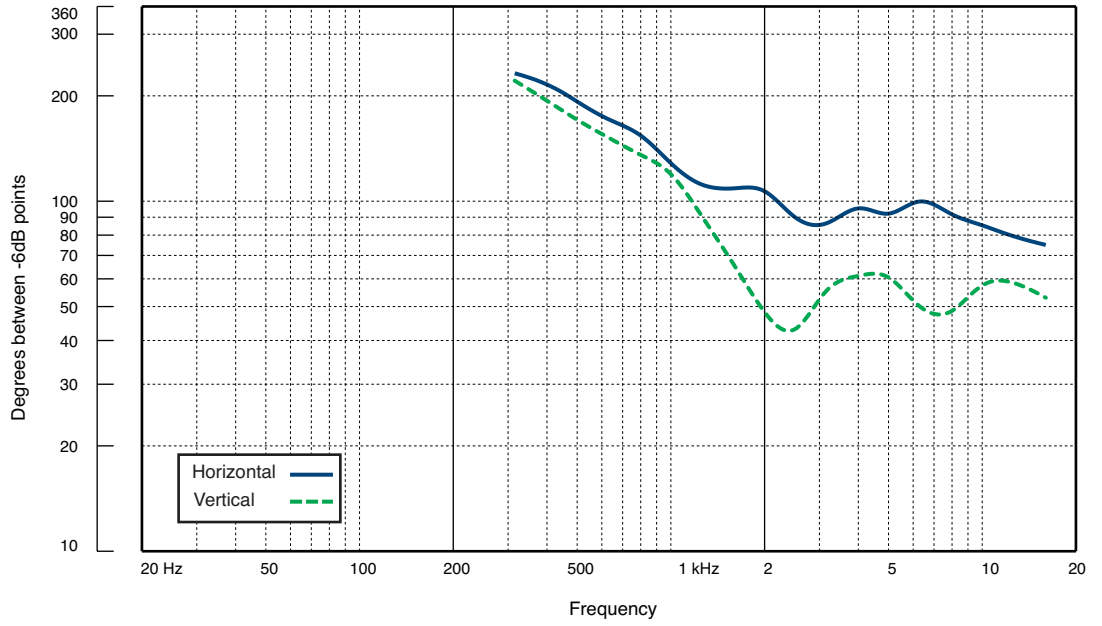

**NUQ SERIES ENGINEERING INFORMATION**

**FLYING AND RIGGING  
HARDWARE**

The cabinet is fitted with rigging points on the top, bottom, sides and rear which allow it to be flown or mounted in a variety of ways to suit differing applications.

An adjustable flying yoke enables the cabinet to be fixed to a ceiling or truss (with optional SC-01 scaffold clamps) with the ability to rotate and angle downwards. The NuQ-TB twin bar extends this system's capabilities by enabling two enclosures to be arrayed together, either from a scaffold bar or mounted on a straight pole or speaker stand.

Swivel brackets allow one or more cabinets to be suspended horizontally. Extender bars can be used to increase the column length by adding further cabinets in a vertical array. A scaffold clamp adapter is also available for truss mounting.

M8 rigging points are provided on the rear panel for use with WB-20B wall brackets, and for use with OmniMount™ 20.5 series brackets. The integral pole mount socket enables the cabinet to be used with standard 35mm tripod stands and poles, or wall-mounted using the universal PB-55 pole bracket.

M10 eyebolts rigging points are also available on the top, sides and bottom to provide an additional method of rigging cabinets in permanent installations.

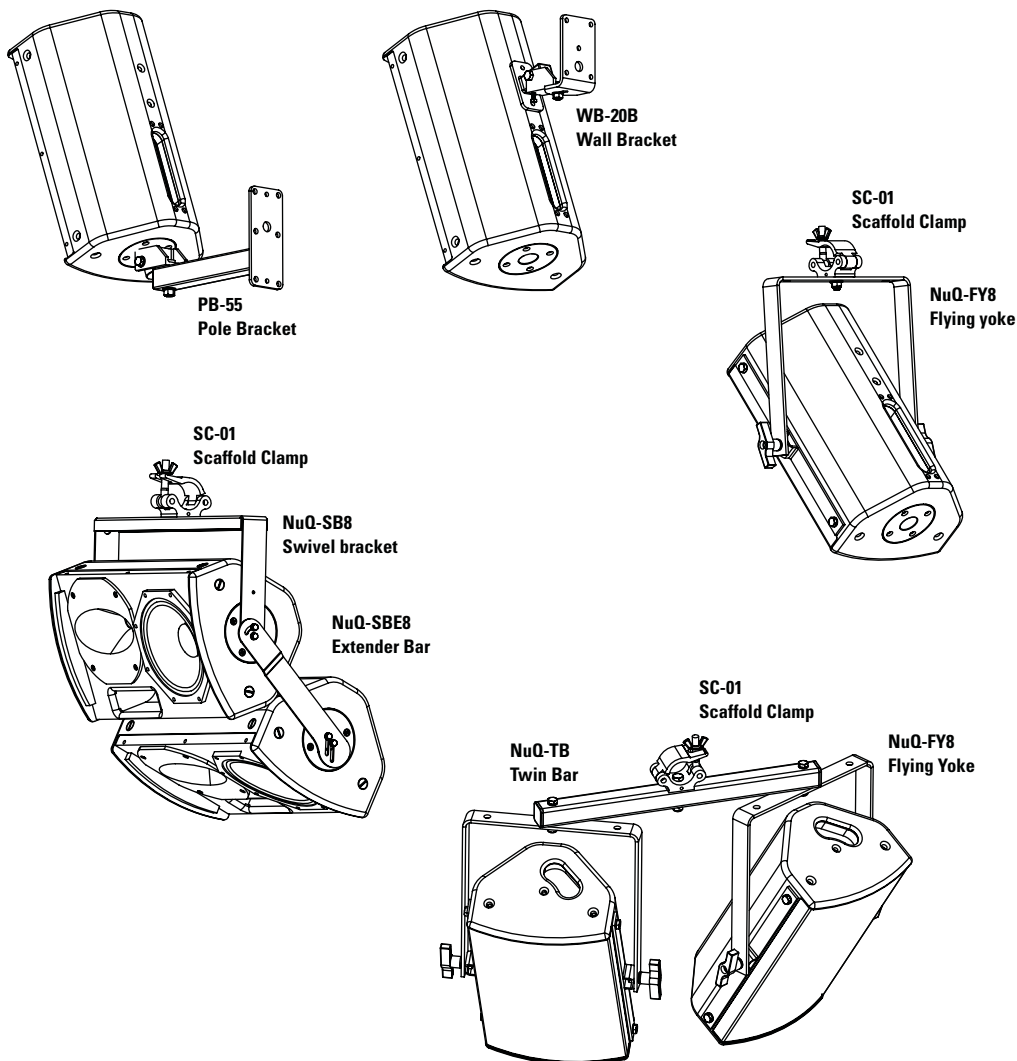

**ARCHITECTURAL  
& ENGINEER'S  
SPECIFICATIONS**

The system shall be of the passive two-way loudspeaker type consisting of one 8" (203mm) LF driver and one 1" (25mm) HF driver on a rotatable Converging Elliptical Waveguide™. Performance specifications of a typical production unit when used with a Turbosound LMS series digital loudspeaker management system shall meet or exceed the following: Frequency response, measured with swept sine wave input, shall be flat within  $\pm 4\text{dB}$  from 60Hz to 20kHz. Nominal dispersion, at -6dB points, shall average  $100^\circ\text{H} \times 60^\circ\text{V}$ . Power handling shall be 250 watts continuous, 500 watts program. Maximum SPL (peak) measured with music program at stated amplifier input shall be 124dB. Dimensions: 464mmH x 272mmW x 220mmD (18.3"H x 10.7"W x 8.7"D). Weight: 9.5kg (20.9lbs). The loudspeaker system shall be the Turbosound NuQ-8. No other loudspeaker shall be acceptable unless submitted data from an independent test laboratory verify that the above combined performance / size specifications are equalled or exceeded.

**DIMENSIONS**

