

## NUQ SERIES ENGINEERING INFORMATION

**The NuQ-12DP is a full range self-powered two-way loudspeaker enclosure incorporating integral amplifiers and control electronics. The use of DSP amplifier technology ensures an exact match between amplifier and speaker for optimum acoustic output, and offers exceptional ease of use by having the entire electro-acoustic system in one convenient, easily transportable physical package. The NuQ-12DP is designed for use in mobile speech and music sound reinforcement applications.**

The NuQ-12DP features a new generation of innovative Class D power amplifier module, utilising revolutionary 96kHz DSP technology to give operating efficiency in excess of 90%.

The two-way NuQ-12DP loudspeaker consists of a front loaded 12" neodymium low frequency driver and a 1.4" neodymium high frequency compression driver on a rotatable 80°H x 50°V HF Converging Elliptical Waveguide™ in a reflex-loaded enclosure.

The comparatively short HF horn flare ensures that the wavefront is shaped smoothly, eliminating reflections in the throat area while giving excellent pattern control. The waveguide can be rotated within the enclosure, making it possible to swap the horizontal and vertical coverage patterns.

The rear panel carries a fully integrated Class D amplifier and control electronics module, and

incorporates high performance limiters set to optimise the continuous power and excursion threshold for the specific loudspeaker model. Two independent amplifier channels power the LF and Hf drivers separately in order to maximise headroom. A Neutrik™ Powercon connector provides mains input to the unit—the switch mode power supply is auto-sensing over a range from 100 volts to 240 volts—and 3-pin XLR's are used for input and parallel link signal connections. RJ45 network connectors enable multiple loudspeakers to be controlled and monitored over a BVNet network using TurboDrive™ software.

The cabinet includes a pole mount socket for use with 35mm poles and speaker stands. Rigging points are provided for use with flying yokes and M10 shoulder eyebolts. It is constructed from pre-bent plywood, which entirely eliminates four cabinet joints and provides additional benefits of superior strength, low weight and reduced internal reflections.

The symmetrical cabinet shape creates an additional role as mirrored left/right monitor wedges as well as for front-of-house applications. It is finished in black semi-matt textured paint; white textured paint is optionally available. A recessed flush handle is provided for easy handling.



### FEATURES

- CEW™ technology**
- Digitally self-powered**
- Class D amplifiers**
- Rotatable HF waveguide**
- Pole mount socket**
- OmniMount™ compatible**

### APPLICATIONS

- Front of house**
- Floor monitor**
- Dry hire and rental**
- Theatre**
- Houses of Worship**
- Corporate / industrial**

<b>DIMENSIONS (HxWxD)</b>	655mm x 373.5mm x 340mm (25.8" x 14.7" x 13.4")	
<b>NET WEIGHT</b>	23kg (50.6lbs)	
<b>COMPONENTS</b>	1 x 12" (305mm) LF driver, 1 x 1.4" (35mm) HF driver on a Converging Elliptical Waveguide™	
<b>FREQUENCY RESPONSE<sup>1</sup></b>	55Hz - 20kHz ±4dB	
<b>NOMINAL DISPERSION<sup>2</sup></b>	80°H x 50°V@-6db points. Rotatable waveguide allows swap of horizontal and vertical pattern	
<b>CALCULATED MAX SPL</b>	127dB continuous <sup>3</sup> , 133dB peak <sup>4</sup>	
<b>CONSTRUCTION</b>	15mm (5/8") birch plywood; rebated, screwed and glued. Finished in black semi-matt textured paint. One recessed carrying handle	
<b>GRILLE</b>	Powder coated perforated steel with acoustically transparent reticulated foam	
<b>CONNECTORS</b>	Input: (1) XLR female, Link: (1) XLR male, pin 2 hot; Neutrik Powercon; (2) RJ45 network port	
<b>AMPLIFIER</b>	<b>TYPE:</b>	Class D inc SMPA and networked DSP
	<b>POWER OUTPUT:</b>	2 x 800 watts continuous @ 8 ohms (1kHz, 0.01% THD)
	<b>DYNAMIC RANGE:</b>	110dB
	<b>INPUT CLIP:</b>	10dBu
	<b>BANDWIDTH:</b>	20Hz - 20kHz ±0.5dB
	<b>POWER REQUIREMENTS:</b>	100V to 240V AC @ 50/60Hz
<b>FLYING HARDWARE</b>	M10 internal rigging points for flying yokes and M10 eyebolts	
<b>OPTIONS</b>	Optional colour: white textured paint	
<b>SPARES AND ACCESSORIES</b>	LS-1221	12" (305mm) LF loudspeaker
	RC-1221	Recone kit
	CD-213.2	1.4" (35mm) HF compression driver
	RD-213.2	Replacement diaphragm
	MG-NuQ12	Replacement grille
	NuQ-FY12	Flying yoke
	PB-55	Wall bracket, pole mount fixing

Notes

<sup>1</sup>Measured on axis

<sup>2</sup>Average over stated bandwidth

<sup>3</sup>Unweighted diode-clipped pink noise. Measured in a half space environment

<sup>4</sup>Verified by subjective listening tests of familiar program material, before the onset of perceived signal degradation

**FREQUENCY RESPONSE**

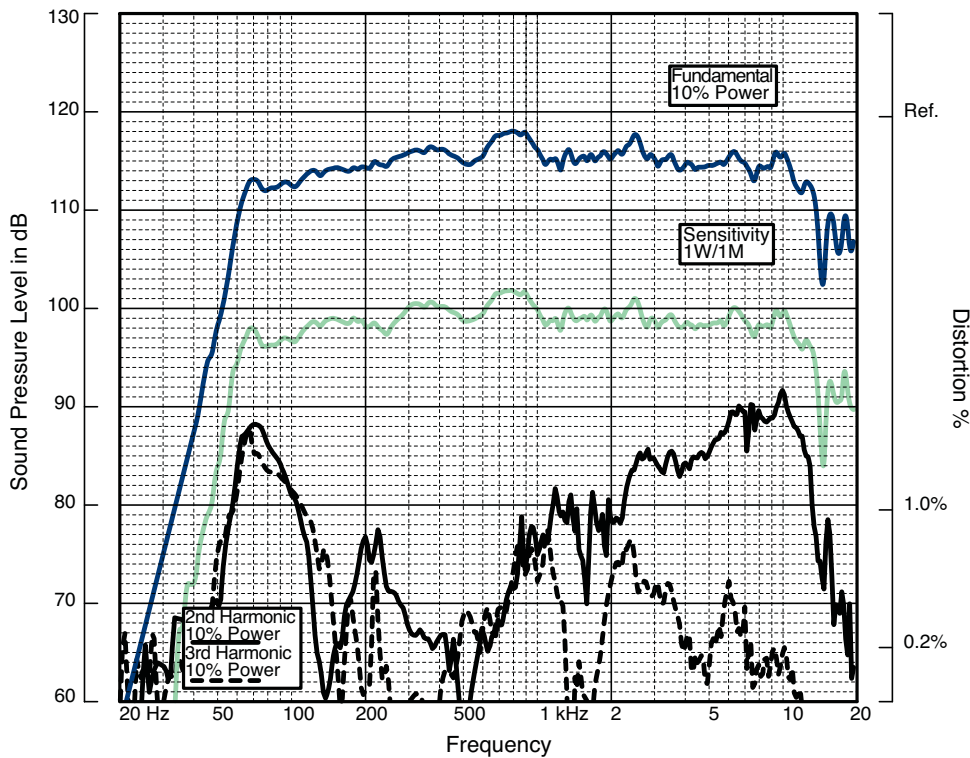

**Impedance** A constant current circuit was used to measure the impedance. **Frequency response** The frequency response shown was obtained by feeding a swept sine wave through an unprocessed loudspeaker system in a half space environment. The position of the microphone was vertically on-axis at a distance of 2 metres, then scaled to represent 1 metre. **2nd & 3rd Harmonic Distortion** Distortion measurements were obtained using an Audio Precision harmonic distortion analysis system and comply with AES recommendations for enclosure measurement (AES paper ANSI S4-26-1984). **Data Conversion** All graphs were digitally generated using the APEX custom software system, designed to translate data derived from Audio Precision 'System One' test equipment into AutoCAD™. This program enables graphical information to be plotted to a high degree of accuracy.

**NOTES ON MEASUREMENT CONDITIONS**

**HORIZONTAL THIRD  
OCTAVE POLARS**

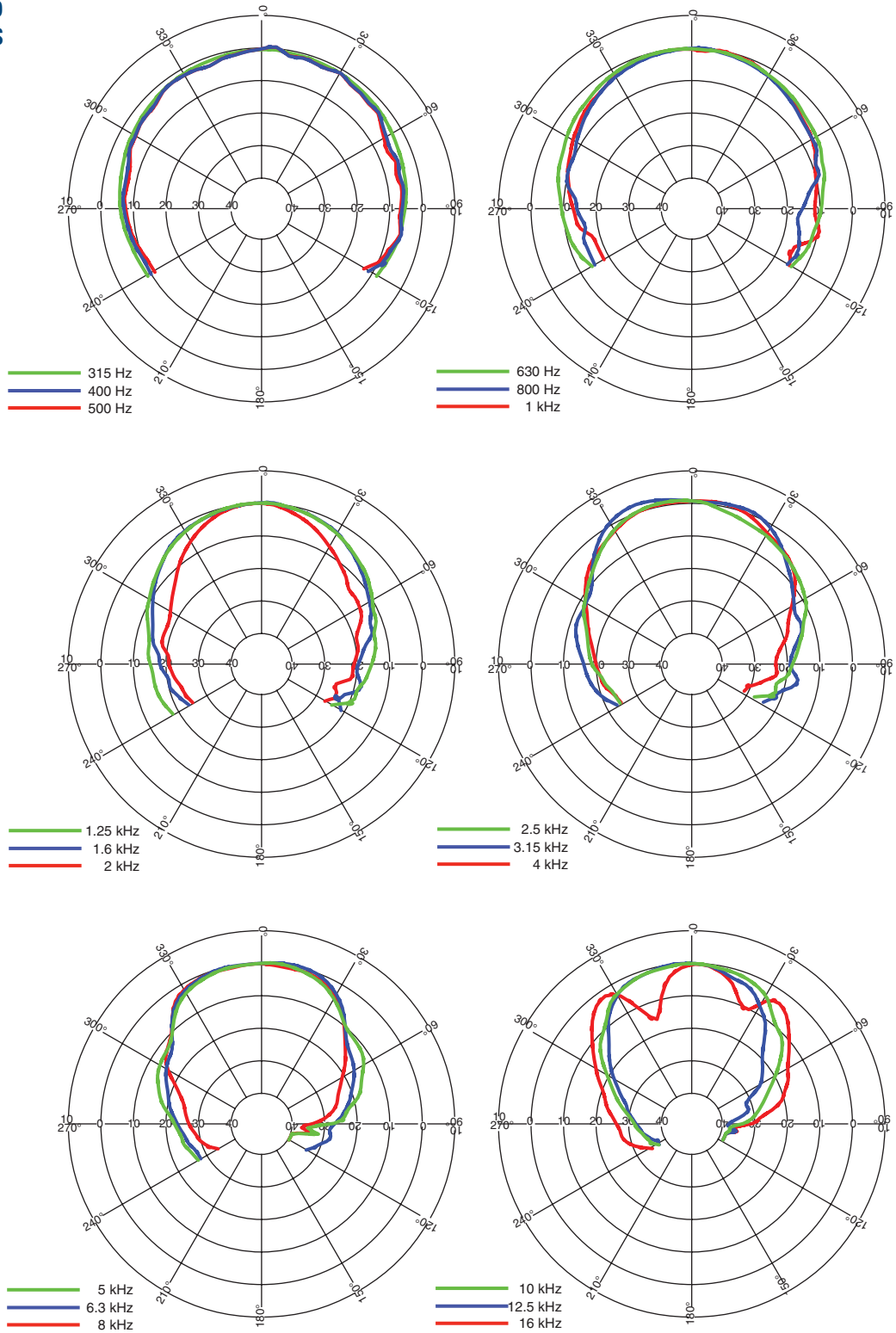

**VERTICAL THIRD  
OCTAVE POLARS**

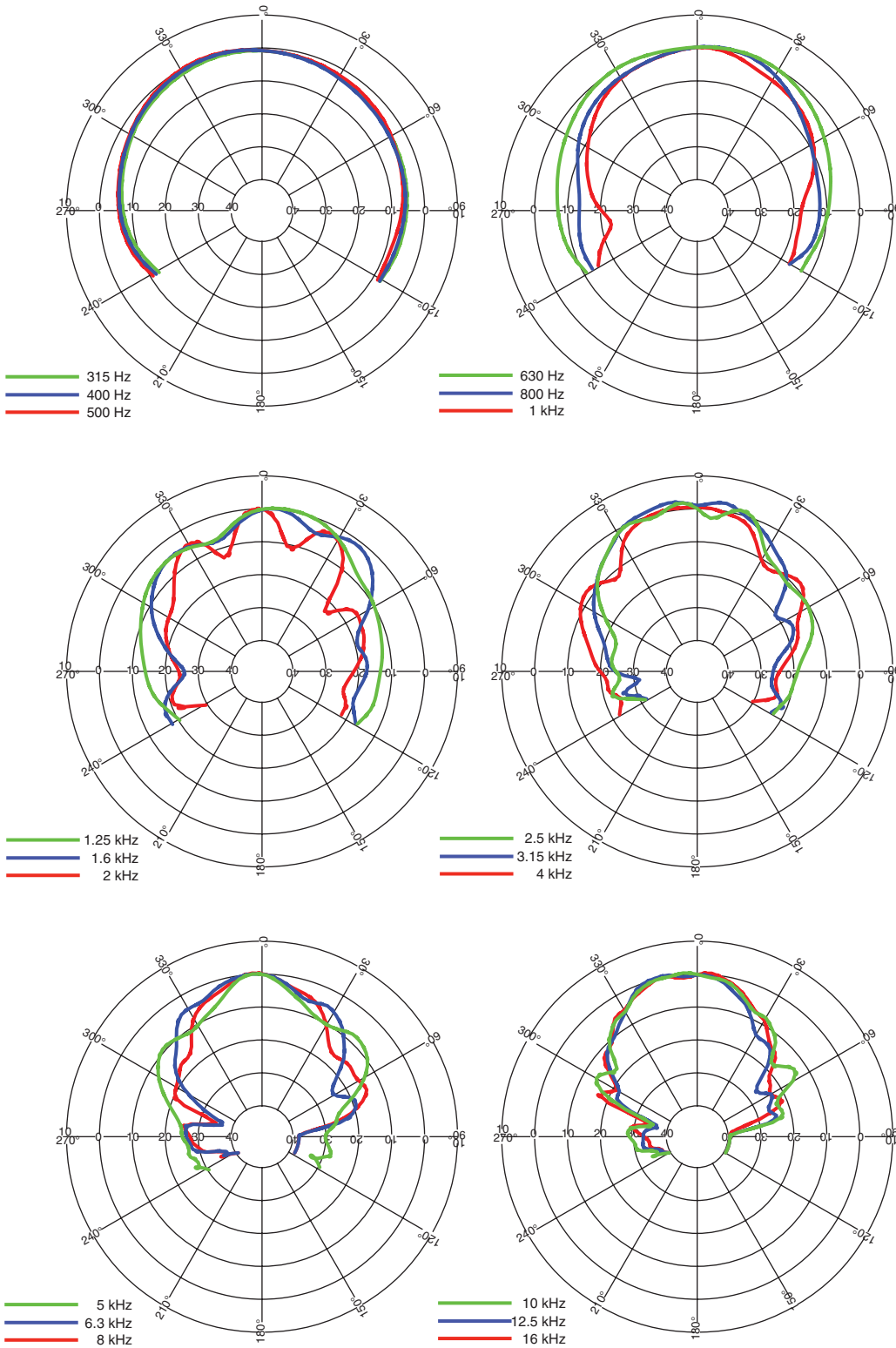

**BEAMWIDTH**

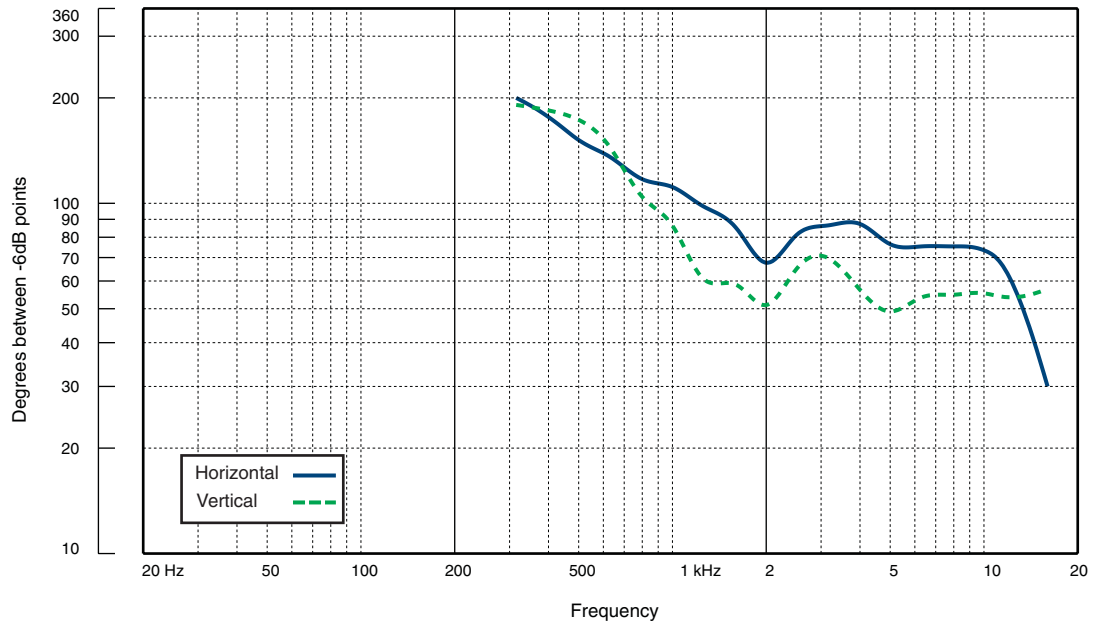

## **NuQ SERIES ENGINEERING INFORMATION**

The cabinet is fitted with rigging points on the top, bottom and sides which allow it to be flown or mounted in a variety of ways to suit differing applications.

An adjustable flying yoke enables the cabinet to be fixed to a ceiling or truss (with optional SC-01 scaffold clamps) with the ability to rotate and angle downwards.

The integral pole mount socket enables the cabinet to be used with standard 35mm tripod stands and poles, or wall-mounted using the universal PB-55 pole bracket.

M10 eyebolts rigging points are also available on the top, sides or bottom to provide an additional method of rigging cabinets in permanent installations.

### **INSTALLATION AND RIGGING HARDWARE**

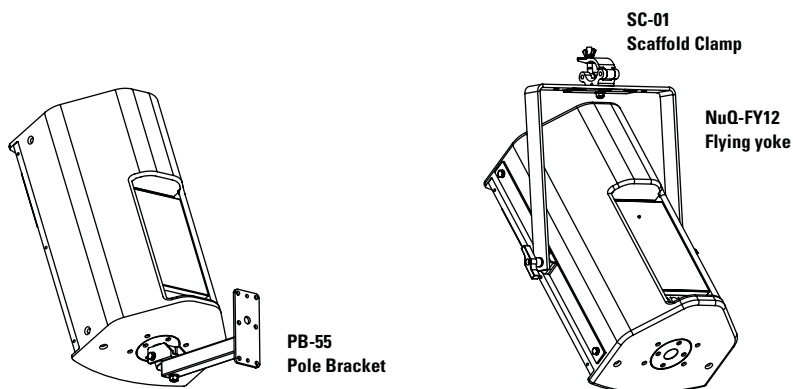

**ARCHITECTURAL  
& ENGINEER'S  
SPECIFICATIONS**

The system shall be of the digitally self-powered, networkable two-way type consisting of one 12" (305mm) LF driver and one 1.4" (35mm) HF driver on a rotatable Converging Elliptical Waveguide™. The integral power amplifier module shall provide Class D amplification, output limiting, and equalisation incorporating frequency responses optimised for speech and music. Performance specifications of a typical production unit shall meet or exceed the following: Frequency response, measured with swept sine wave input, shall be flat within  $\pm 4\text{dB}$  from 55Hz to 20kHz. Nominal dispersion, at -6dB points, shall average  $80^\circ\text{H} \times 50^\circ\text{V}$ . Maximum SPL (peak) measured with music program at stated amplifier input shall be 133dB. Dimensions: 655mmH x 373.5mmW x 340mmD (25.8"H x 14.7"W x 13.4"D). Weight: 23kg (50.6lbs). The loudspeaker system shall be the Turbosound NuQ-12DP. No other loudspeaker shall be acceptable unless submitted data from an independent test laboratory verify that the above combined performance / size specifications are equalled or exceeded.

**DIMENSIONS**

